

## INSTALLATION AND CONFIGURATION MANUAL ABRAMS LED TOUCH LIGHT SERIES

**MODEL: TLC-9300**

### WARNING:

FAILURE TO INSTALL OR USE THIS PRODUCT ACCORDING TO MANUFACTURER'S RECOMMENDATIONS MAY RESULT IN PROPERTY DAMAGE, SERIOUS INJURY, AND/OR DEATH.

### IMPORTANT:

PLEASE READ ALL OF THE FOLLOWING INSTRUCTIONS BEFORE INSTALLING YOUR NEW ABRAMS BLASTER SERIES HIDEAWAY.

- PROPER INSTALLATION OF THIS PRODUCT REQUIRES THE INSTALLER TO HAVE A GOOD UNDERSTANDING OF AUTOMOTIVE ELECTRONICS, SYSTEMS AND PROCEDURES.
- THIS PRODUCT CONTAINS HIGH-INTENSITY LEDS. DO NOT STARE DIRECTLY INTO THESE LIGHTS. MOMENTARY BLINDNESS AND/OR EYE DAMAGE COULD RESULT.
- DO NOT INSTALL THIS PRODUCT OR ROUTE ANY WIRES IN THE DEPLOYMENT AREA OF YOUR AIR BAG. EQUIPMENT MOUNTED OR LOCATED IN THE AIR BAG DEPLOYMENT AREA WILL DAMAGE OR REDUCE THE EFFECTIVENESS OF THE AIR BAG, OR BECOME A PROJECTILE THAT COULD CAUSE SERIOUS PERSONAL INJURY OR DEATH. REFER TO YOUR VEHICLE OWNER MANUAL FOR THE AIR BAG DEPLOYMENT AREA. THE USER/INSTALLER ASSUMES FULL RESPONSIBILITY TO DETERMINE PROPER MOUNTING LOCATION, BASED ON PROVIDING ULTIMATE SAFETY TO ALL PASSENGERS INSIDE THE VEHICLE.
- IF MOUNTING THIS PRODUCT REQUIRES DRILLING HOLES, THE INSTALLER MUST BE SURE THAT NO VEHICLE COMPONENTS OR OTHER VITAL PARTS COULD BE DAMAGED BY THE DRILLING PROCESS. CHECK BOTH SIDES OF THE MOUNTING SURFACE BEFORE DRILLING BEGINS. ALSO DE-BURR ANY HOLES AND REMOVE ANY METAL SHARDS OR REMNANTS. INSTALL GROMMETS INTO ALL WIRE PASSAGE HOLES.

- INSPECT AND OPERATE THIS PRODUCT REGULARLY TO CONFIRM ITS PROPER OPERATION AND MOUNTING CONDITION. DO NOT USE A PRESSURE WASHER TO CLEAN THIS PRODUCT.
- FOR THIS PRODUCT TO OPERATE AT OPTIMUM EFFICIENCY, A GOOD ELECTRICAL CONNECTION TO CHASSIS GROUND MUST BE MADE. THE RECOMMENDED PROCEDURE REQUIRES THE PRODUCT GROUND WIRE TO BE CONNECTED DIRECTLY TO THE NEGATIVE (-) BATTERY POST.
- IT IS RECOMMENDED THAT THESE INSTRUCTIONS BE STORED IN A SAFE PLACE AND REFERRED TO WHEN PERFORMING MAINTENANCE AND/OR REINSTALLATION OF THIS PRODUCT.
- FAILURE TO FOLLOW THESE SAFETY PRECAUTIONS AND INSTRUCTIONS COULD RESULT IN DAMAGE TO THE PRODUCT OR VEHICLE AND/OR SERIOUS INJURY TO YOU AND YOUR PASSENGERS!
- IF THIS PRODUCT USES A REMOTE DEVICE TO ACTIVATE OR CONTROL THIS PRODUCT, MAKE SURE THAT THIS CONTROL IS LOCATED IN AN AREA THAT ALLOWS BOTH THE VEHICLE AND THE CONTROL TO BE OPERATED SAFELY IN ANY DRIVING CONDITION.
- DO NOT ATTEMPT TO ACTIVATE OR CONTROL THIS DEVICE IN A HAZARDOUS DRIVING SITUATION

### DIMENSIONS:

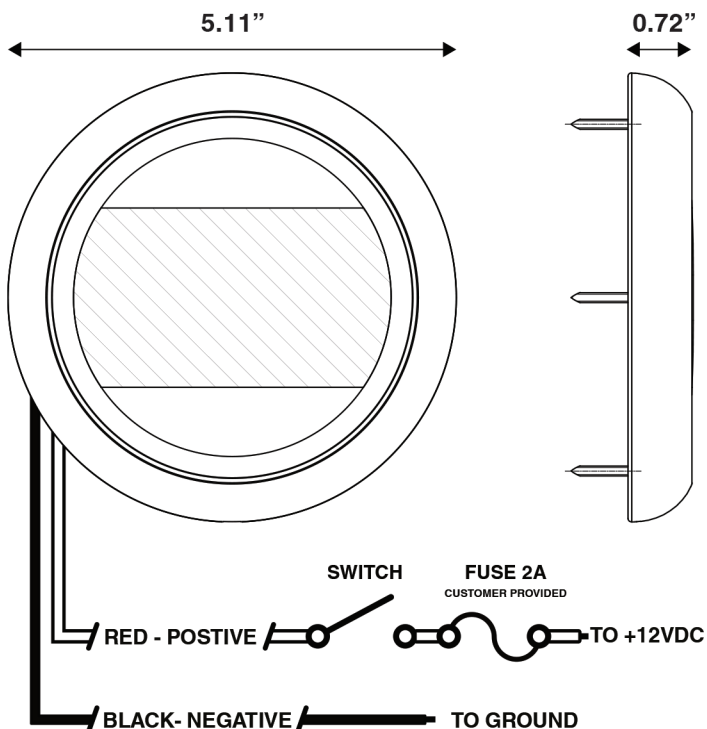

### WIRING INSTRUCTIONS

1. WITH THE POWER TO THE EXISTING LIGHT TURNED OFF, REMOVE AND RETAIN THE HARDWARE SECURING THE LIGHT TO THE VEHICLE.
  2. DISCONNECT THE EXISTING WIRES FROM THE LIGHT BEING REPLACED. BE SURE TO NOTE THE COLOR AND FUNCTION OF EACH WIRE.
  3. USING THE WIRING DIAGRAM SHOWN , CONNECT THE WIRES FROM THE REPLACEMENT LIGHT TO THEIR APPROPRIATE DESIGNATION.
- \*NOTE: BE SURE TO FOLLOW THE FUSING GUIDELINES SHOWN.
4. SECURE THE REPLACEMENT LIGHT TO THE VEHICLE USING THE EXISTING HARDWARE.

### PACKAGE CONTENTS:

- LED TOUCH LIGHT
- SCREWS
- PRODUCT MANUAL

### WIRING INSTRUCTIONS FOR TOUCH LIGHT

<b>BLACK</b>	NEGATIVE/GROUND
<b>RED</b>	POSITIVE

### ABRAMS LED TOUCH LIGHT SPECIFICATIONS

<b>INPUT VOLTAGE</b>	10-30VDC
<b>WORK CURRENT</b>	12V - 0.85A (MAX) 24V - 0.48A (MAX)
<b>WATERPROOF</b>	IP67

### Recommend Operation Environment

Ambient Temperature: -30 to 50  
 Relative Humidity: 10 to 85% , non-condensing

## INSTALLATION AND CONFIGURATION MANUAL ABRAMS LED TOUCH LIGHT SERIES

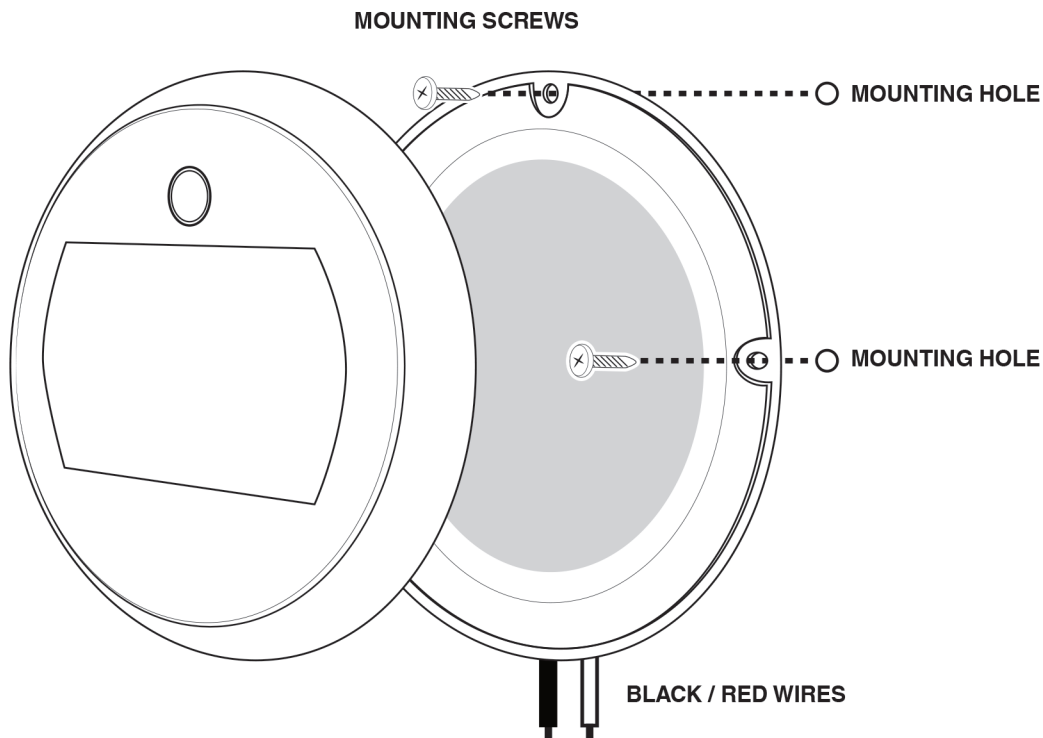

### MOUNTING

1. Remove the Light cover from the base / bracket of the light.
2. Using the measurements on the base / bracket, mark the locations of 3 of the mounting holes to be drilled into the mounting surface and drill the holes using the appropriate drill bit size.
2. Place the light onto the mounting surface, line the three mounting holes up with the mounting holes in the light and mark off the wire holes. Ensure the wires are in the desired location before securing the light to the mounting surface.
4. Remove the light and drill the second and third set of mounting holes.
5. Using the wiring diagram on page one, connect the wires to their appropriate designation.

### TROUBLESHOOTING:

The **TOUCH LIGHT** series has been factory tested and approved, If the functions of the device fail, please check the following:

After connecting the power supply, be sure that the power source end is joined in the correct way. then, make sure that there is no short circuit power occurring.

Ensure Power switch is turned to ON position.

\*\*IF YOU REQUIRE ADDITIONAL INFORMATION AND/OR VIDEO AND USER GUIDES, PLEASE VISIT [WWW.ABRAMSMFG.COM/SUPPORT](http://WWW.ABRAMSMFG.COM/SUPPORT) OR CALL ABRAMS CUSTOMER SUPPORT 844.9.ABRAMS

### WARRANTY (2 YEAR WARRANTY)

THIS PRODUCT WAS TESTED AND FOUND TO BE OPERATIONAL AT THE TIME OF MANUFACTURE. PROVIDED THIS PRODUCT IS INSTALLED AND OPERATED IN ACCORDANCE WITH THE MANUFACTURER'S RECOMMENDATIONS, ABRAMS GUARANTEES THIS PRODUCT FOR A PERIOD OF 2 YEARS FROM THE DAY OF PURCHASE OR DELIVERY, WHICH EVER IS LATER. UNITS DEMONSTRATED TO BE DEFECTIVE WITHIN THE WARRANTY PERIOD WILL BE REPLACED. IMPROPER INSTALLATION OR USE OF INAPPROPRIATE OR INADEQUATE WIRING OR CIRCUIT PROTECTION CAUSES THE WARRANTY TO BE VOID. FAILURE OR DESTRUCTION OF THE PRODUCT RESULTING FROM ABUSE OR UNUSUAL USE AND/OR ACCIDENTS IS NOT COVERED BY THIS WARRANTY. ABRAMS SHALL IN NO WAY BE LIABLE FOR OTHER DAMAGES INCLUDING CONSEQUENTIAL, INDIRECT OR SPECIAL DAMAGES WHETHER LOSS IS DUE TO NEGLIGENCE OR BREACH OF WARRANTY. ABRAMS MAKES NO OTHER EXPRESS OR IMPLIED WARRANTY INCLUDING, WITHOUT LIMITATION, WARRANTIES OF FITNESS OR MERCHANTABILITY, WITH RESPECT THIS PRODUCT.

